

How to Build Biomass Chopper – Cutter

Notes, Parts List and Drawings

Safety First !
Keep Shield on
When Chopping

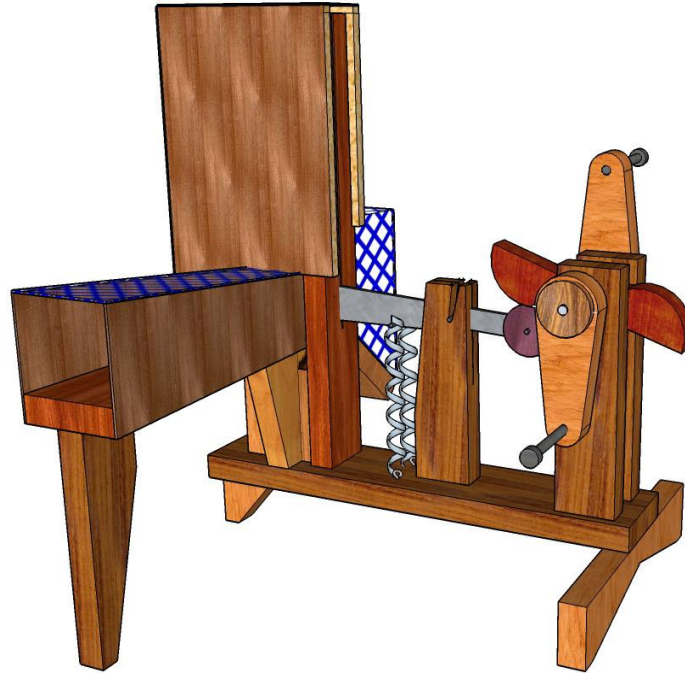

Safety First !
Keep Shield on
When Chopping

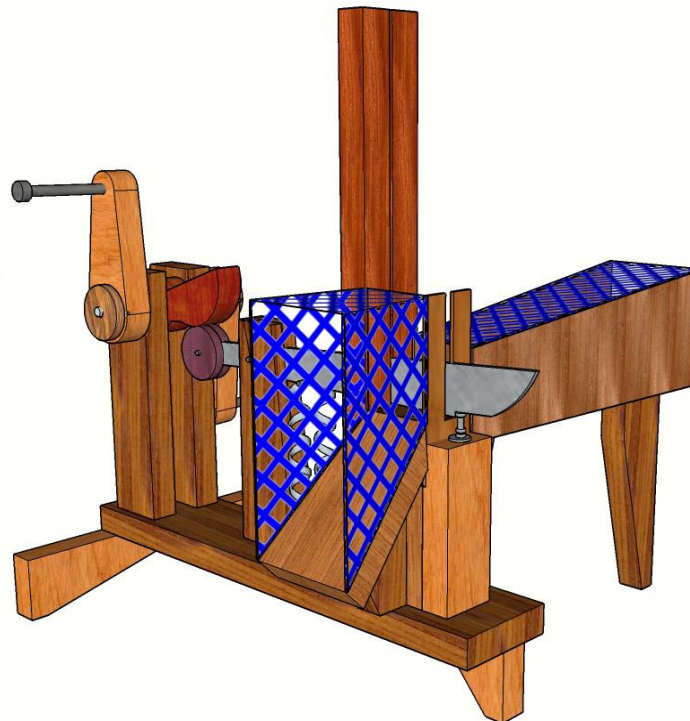

The biomass chopper/cutter was designed to cut both wet and dry biomass and to accomplish several goals. The objectives were low-cost, easy to build using mostly hand tools, easy to operate, easy to maintain and requires no welding. Below are a few comments regarding use and construction.

1. The dimensions are based on a standard lumber size of 3 1/2" wide X 1 1/2" thick material, and 5 1/2" wide X 1 1/2" thick material. The chopper can be constructed using softwood except for the chopping block (J-3) which should be hardwood.
2. We suggest first building the individual assemblies for the machete (F), the cam assembly (B), the chopping block assembly (J), the feed chute assembly (K), the exit chute (LL), the base assembly consisting of parts D, P and R, and the safety shield (M).

3. **Cam Assembly** consists of the cam (B), the cam axle (T-1), (two-T-2 Pins) and (one-T-3 Pin). We suggest using 3/16" pins to retain both the cam and handles. However, you can use whatever appropriate size pin you have available. Adjust the slot width and the holes in the cam axle and the handles appropriately. Place a washer on each side of the cam and on the inside of each handle. See picture to the left.

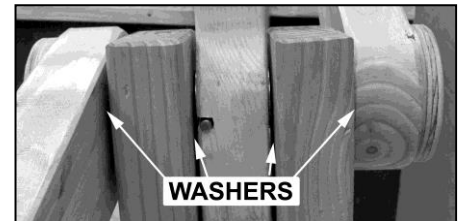

4. **Cam Axel (T-1):** As you go through the assembly process, we suggest using the axle without drilling the holes for the axle pins that hold the cam and the handles. At the end of the assembly process, you can then accurately locate the position for each pin and drill to fit the pins.
5. **Handle (A)** and handle retention plate (AA) are shown with rounded ends. Rounded ends are not necessary for proper operation, and you can easily use square corners for both the handle and the handle retention plate (A-1 & AA-1). Use care when cutting the slot for the axle pin so the pin fits snugly.

Drill a 7/16" hole through the handle to hold the handle bolt and force thread the bolt all the way into the hole. Position two washers on the axle between the cam support post (C) and the handle (A).

6. **Cam Support Post:** if you have hardwood available, we suggest using it for the support post to accommodate a good bearing surface for the cam axle. However, we have successfully used softwood and it seems to work fine as a bearing surface. There is very little loading on the cam axle.

From the top, drill a small hole down into the axle hole. This is to allow for lubrication of the cam axle. See picture to the right.

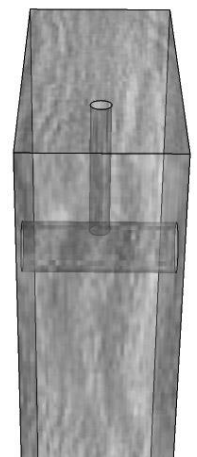

7. **Machete Assembly:** we used two machetes with a length of 22" & 23" for testing. However, machetes are made to several different lengths and this design will easily accommodate various lengths. Even with different lengths of machetes we recommend maintaining 4 3/4" to 5" between centers for the roller disk (F2) and the pivot bolt. We also suggest maintaining a distance of 3" between the pivot bolt and the spring support bolt.

Machetes are manufactured for various hardness to maintain good sharpness. Some can be easily drilled using a normal metal cutting drill bit. However, some are extremely hard and impossible to drill. This problem is easily solved by heating the spot at which you wish to drill to a "Cherry Red" color then allowed to air cool. This process will soften the metal sufficiently to allow easy drilling. Be certain to heat both sides of the desired spot evenly to prevent warping the machete. We easily accomplished this using a simple propane torch, one on each side.

When attaching the pivot bolt and the spring support bolt (T-4) use a lock washer to maintain tightness.

Warning do not over torque the nut when tightening both the pivot bolt and spring support bolt. Over torturing will weaken the metal in between the two nuts and cause the bolt to prematurely fail from the heavy pounding forces.

Before you cut the slot into the machete post we suggest you drill a hole in the top of the machete support post to accept the nuts holding the pivot bolt. Typically, a diameter of about $\frac{3}{4}$ ". See picture to the right.

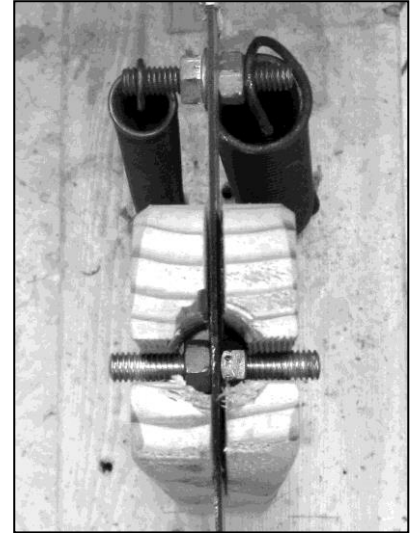

8. **Machete Roller Disk (F-2):** should be constructed from a $\frac{1}{2}$ " thick laminated material like plywood or perhaps heavy-duty plastic or fiberglass. You can glue two $\frac{1}{4}$ " solid wood disk together positioned with the grain crossing. Do not use solid wood. There is a very heavy pounding force on this disk, and it will easily shatter if made from solid wood.

9. **Machete stop bolt and support post (G):** The $\frac{1}{2}$ " bolt may appear to be oversized for this application. However, the bolt takes a great deal of pounding from the machete and the large size is required to withstand the pounding forces. The $\frac{7}{16}$ " hole is deliberately undersized to allow the forced threading of the bolt into the support post. Be sure to use a large washer underneath the double nut to prevent the bolt from creeping down into the post. Final adjustment for the cutting height of the machete is achieved by the adjustment of this bolt. The double nut assures that the bolt will remain accurately adjusted.

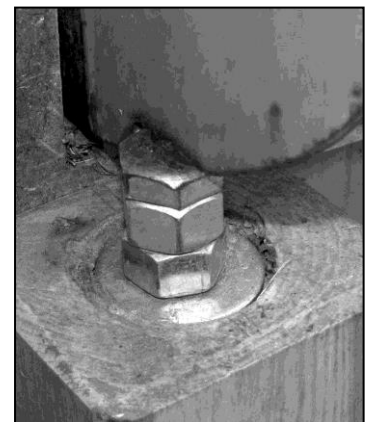

10. **Feed Chute (K):** you can pre-assemble the feed chute (K) but leave the top off until you have attached the chute to the main chopper. The top access is necessary to install the screws that hold the chute to the chopper, and hold the front leg of the chute.

11. **Exit Chute (L):** you can pre-assemble the exit chute (L). Attach it using wood screws. If you need to remove the chopping block (J-3), you first must remove the exit chute to allow easy access to (J-3).
12. **Safety Shield (M):**
The Machete Guard Assembly uses a frame from 1/2" X 1/2" wood frame and the sides can be made from wood or metal and can be solid or perforated. Make sure it slips easily over the machete guidepost.
13. **Chopping Block (J-3)** Make certain to construct the chopping block (J-3) so the grain is parallel to the surface of the machete as opposed to cross-grain. This will maximize the life of the chopping block. See drawing for (J-3). The chopping block is designed with 4 cutting surfaces. If one surface becomes damaged or unusable, simply remove the chopping block and rotate it 90°, and reinstall. Remove the exit chute (L) to gain access for removal of (J-3).

14. **Install Cam Assembly:** With the cam assembly installed in both cam support post (C), position the cam support posts 1 1/2" from the end of the base plate and centered side to side. Using a pencil, draw a line around the base of the two support posts. Drill four holes to accept wood screws through the base plate per the diagram to the right for the two penciled locations.

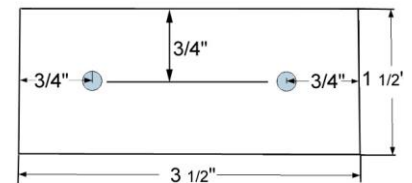

15. **Install Machete Assembly:** Install the machete assembly in the machete support post and position the post so the rotating cam is centered on the rotating disk at the end of the machete. Referring to the "Positioning Diagram" on page 5, adjust dimension Y to about 5". Dimension Y is a starting point, and you may need to adjust this slightly for the proper fit. Using a pencil, draw a line around the base of the support post. Repeat the drilling procedure described in note 14.
16. **Install Chopping Block Assembly (J, H & W):** First, make certain the machete is installed in the machete support post. After you have assembled parts J, H & W together as an assembly, position it so the machete strikes the chopping block in the flat section of the machete before it begins to curve upward. Referring to the "Positioning Diagram", dimension X will be approximately 6" but will vary depending on the actual curvature of your specific blade. Fasten using wood screws from the bottom of base plate (D) and use the marketing procedure in note 14. Also, make certain the machete is located in the center of the machete guidepost (H) to allow smooth operation.

The shape at the far end of the machete can vary considerably. After you have positioned the chopping block assembly for a proper cut from the machete, i.e. using the flat part of the machete before it begins to curve upward, you will need to grind a flat spot at the location where the machete strikes the machete stop bolt. Make certain to grind perfectly flat, i.e. perpendicular to the face of the

machete. The stop bolt receives a tremendous amount of pounding and if the edge of the machete is sharp it can cut into the head of the stop bolt.

17. **Install the Stop Bolt Assembly (G):** install the stop bolt assembly using wood screws so it rests on the base and attaches to the chopping block assembly (J).
18. **Machete Safety:** any chopper using a knife can be dangerous and this is no exception. To minimize danger from the non-cutting edges it is important to dull the sections marked below. Also, it is very important to keep the safety shield (M) installed at all times during the cutting operation.

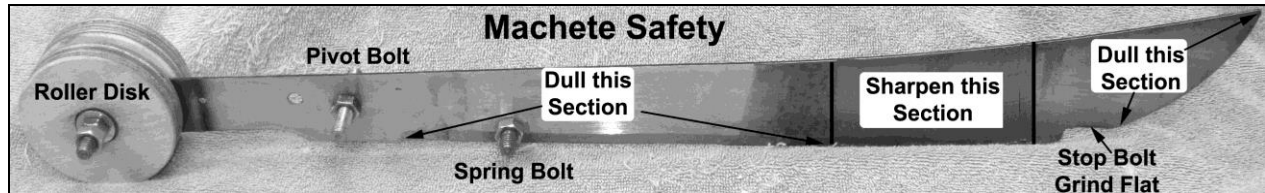

19. With everything assembled and adjusted for a good fit, now is the time to properly locate the axel pins on the axle shaft. Drill the axel to accept the pins.

20. Locate the screw-eyes that holds the bottom end of the springs so the spring moves smoothly and does not rub against the support post when the machete is rotated. Drill a small hole beside the screw-eye to accept a string used to assist stretching the spring to the screw-eye.

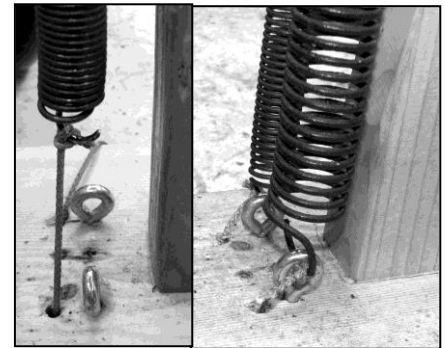

21. Lubricate the axle using the oil holes in the top of support post (C). Also, lubricate the roller disk (F-2).
22. If you plan on using an electric motor or bicycle to power the chopper remove one of the handles and replace it with an appropriate pulley or chain sprocket. Our recommendation is that you do not rotate the chopper any faster than 60 to 90 rpm for optimal cutting.
23. Depending on your particular usage you may need to securely fasten the chopper to a solid structure like a tabletop or mounting stand, particularly if you motor the unit.
24. We recommend coating the feed chute and exit chute with a light oil or moisture protection substance.

Safety First !
 Keep Shield on
 When Chopping

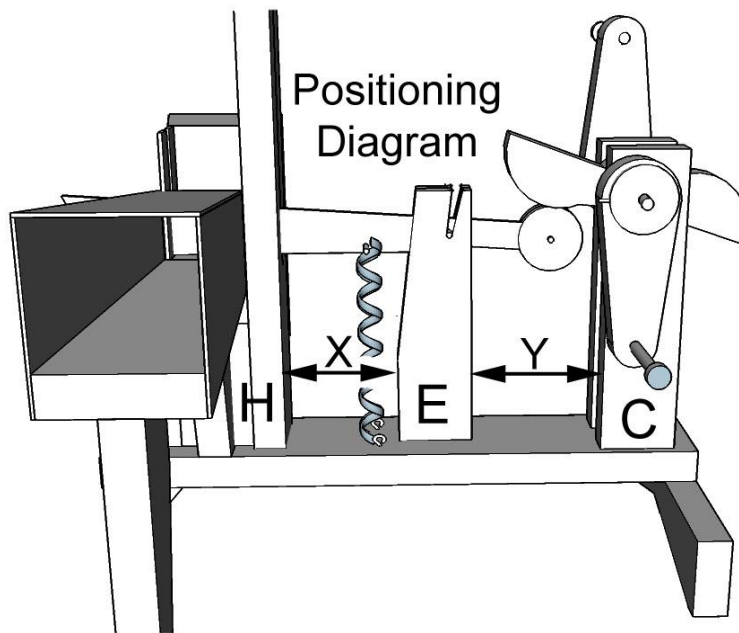
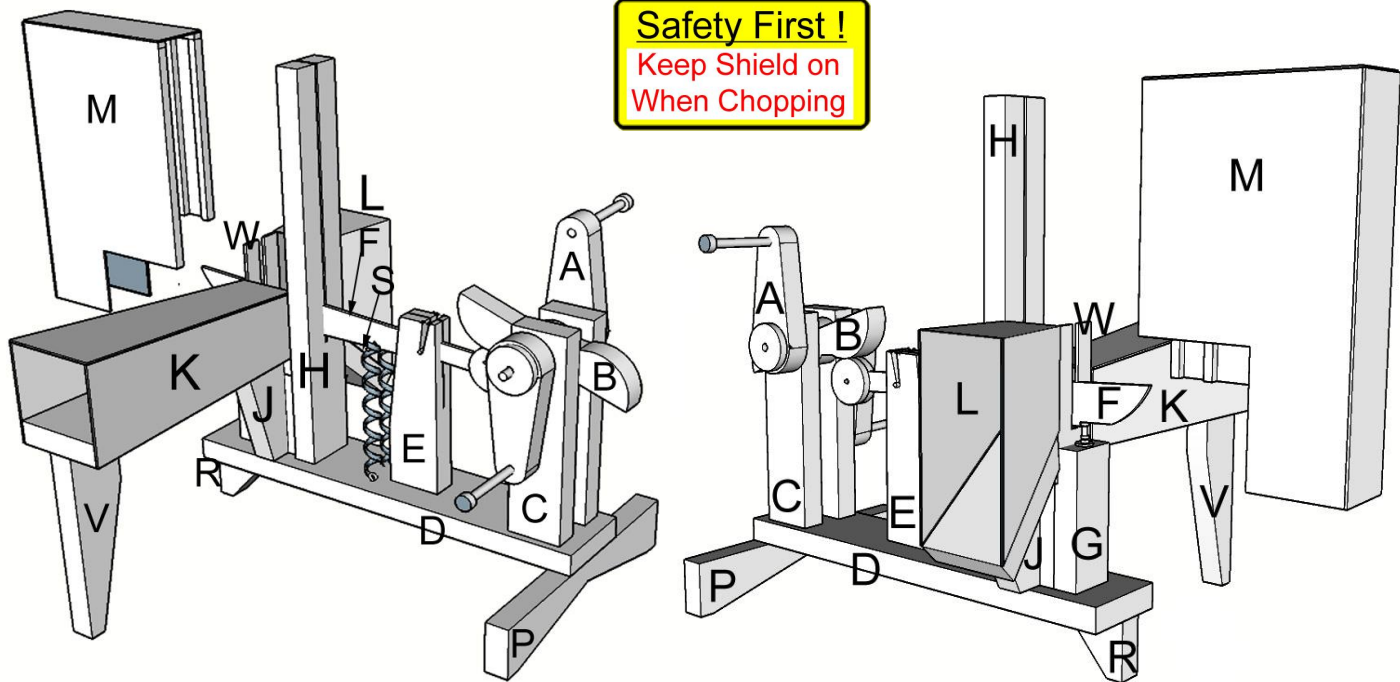

PART	PCS	DESCRIPTION
Wood	2	8' X 3 1/2" X 1 1/2"
Wood	1	5' X 5 1/2" X 1 1/2"
Wood	1	10' of 1/2" X 1/2" framing for the safety shield.
Stock	1	Approximately 5 ft ² of 1/8" material for safety shield
Stock	1	Approximately 3 ft ² of 1/8" material for feed chute and exit chute

Bolts	6	1 pcs 1/2" X 4 1/2" threaded machine bolt, two nuts, one washer (machete stop) 2 pcs 1/2" X 5 1/2" machine bolt (handle) 1 pcs 5/16" X 2" threaded bolt, two nuts, one lock washer (pivot bolt) 1 pcs 5/16" X 2" threaded bolt, two nuts, one lock washer (spring) 1 pcs 5/16" X 2 1/2" smooth shaft bolt, two nuts, 4-washers (roller disk)
A	2	Handle Arm, cut from 1 1/2" X 3 1/2" X 9 1/2" stock, with 1/2" hole and 3/16" slot. See the drawing for hole locations. 1/2" x 5 1/2" bolt threaded into 7/16" hole.
AA	2	Handle retaining plate, 1/2" x 3" Diameter Disk with 1/2" center hole
A-1	2	Alternate Square Handle Arm, cut from 1 1/2" X 3 1/2" X 9 1/2" stock, with 1/2" hole and 3/16" slot. See the drawing for hole locations. 1/2" x 5 1/2" bolt threaded into 7/16" hole.
AA-1	2	Alternate square handle retaining plate, 1/2" x 3 1/2" square with 1/2" center hole
B	1	Cam, cut from 12" X 3 1/2" X 1 1/2" stock, smooth the edges and surfaces.
C	1	Cam Support Post, 1 1/2" X 5 1/2" X 14", for lubrication of the cam axel drill a small hole down into the axle hole from the top of the post. See note 6 above.
D	1	Base Plate, 1 1/2" X 5 1/2" X 28"
E	1	Machete Support Post, 1 1/2" x 3 1/2" x 12", with 3/16" slot centered on edge, cut 6" down from top.
F	1	Machete Assembly,
F-1	1	22' or 23" Machete with three 5/16" holes, see drawing
F-2	2	Machete Roller Disk, 3" diameter from 1/2" laminated stock with 5/16" center hole.
G	1	Machete stop post, 1 1/2" X 3 1/2" X 8" with 4 1/2" x 1/2" threaded machine bolt centered on top. Attach to assembly (J)
H	1	1 1/2" X 3 1/2" X 27" Machete guidepost, with 3/16" slot centered on stock and cut 18" down from the top. Attach to assembly (J)
J	1	Chopping Block Assembly
J-1	1	Feed chute base, 1 1/2" X 3 1/2" X 18" x 5 1/2", see drawing for angle cuts
J-2		Feed Chute Support Post, cut from 7 1/2" X 3 1/2" stock. See drawing for angle cut
J3	1	Chopping block, 3" wide x 3" tall x 3 1/2" side-to-side, hardwood chopping block with the grain perpendicular to the machete knife edge. See drawing
J4	2	1 1/2" X 3 1/2" X 6", chopping block support post, fasten two pieces together to support the chopping block
J-5	1	Exit chute base, 1 1/2" thick X 3 1/2" tapered down to 5 1/2" X 8" long, see drawing for angle cut.
J-6	1	Exit chute base support post., Cut from a 1 1/2" X 3 1/2" X 6 7/8" stock, see drawing for angel cuts
K	1	Feed chute assembly

K-1	2	Feed chute side, 1/8" x 6 1/2" x 18" x 4 1/2"
K-2	1	Feed chute top, 1/8" x 6 3/4" x 18" x 4 3/4", can be solid or perforated material.
L	1	Exit Chute Cage. Use whatever material you have available. Perforated material is not required but does it help when viewing the cutting operation and clean up.
M	1	Machete Guard Assembly, the frame is from 1/2" X 1/2" wood frame but the sides can be made from wood or metal, and can be solid or perforated
M-1	1	Machete Guard Side, 1/8" x 11 1/2" x 20", see drawing for cutout
M-2	1	Machete Guard Side, 1/8" x 11 1/2" x 20", see drawing for cutout
M-3	1	Machete Guard Rear, 1/8" x 3 7/8" x 20"
M-4	1	Machete Guard Top, 1/8" x 3 7/8" x 11 1/2"
P	1	Front foot, 1 1/2" X 3 1/2" X 18", see drawing for angle cut
R	1	Rear Foot, 1 1/2" X 3 1/2" X 4", see drawing for angle cut
S	2	Spring, select coil springs that provide sufficient cutting force for your biomass. Best not to overdue the cutting force to minimize the pounding forces on the chopper.
T-1	1	Cam Axle, 1/2" x 15" Steel Shaft, three holes for 3/16" pins, see drawing B
T-2	2	Handle Pin 3/16" x 3" Steel
T-3	1	Cam Pin, 3/16" x 3" Steel
T-4	1	Machete pivot, 5/16" x 2 1/2" threaded bolt, two nuts, one lock washer
T-5	1	Machete Roller Disk Support Bolt for (F-2), 5/16" x 2", two nuts for locking
T-6	2	Handle Bolt 1/2" x 5 1/2" threaded into an 7/16" hole
V	1	Feed chute support leg, cut from, 1 1/2" X 3 1/2" X 12 1/2", see drawing for angle cut
W	1	Outside machete shield 3" X 14" X 1/8" or greater thickness, See drawing for slot
Washer	4	1/2" washer, two for both sides of the cam and one for the inside of each handle, part B
Washer	4	5/16", one for each side of the two roller disk (F-2)
Fasteners	26	Wood screws, 3 1/2" long
Fasteners	2	Wood screws, 4" long, Attaches Chopping Block

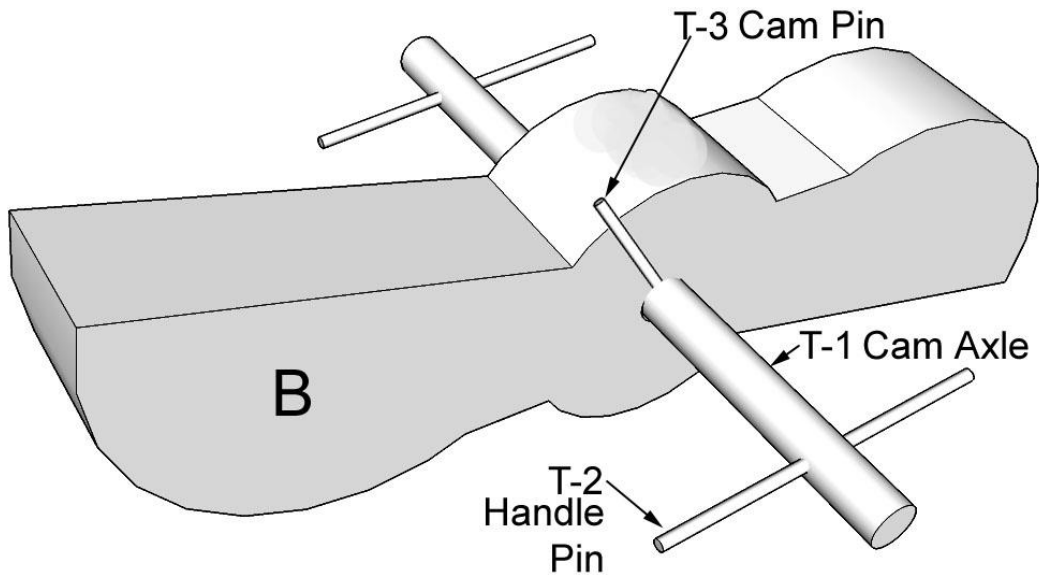
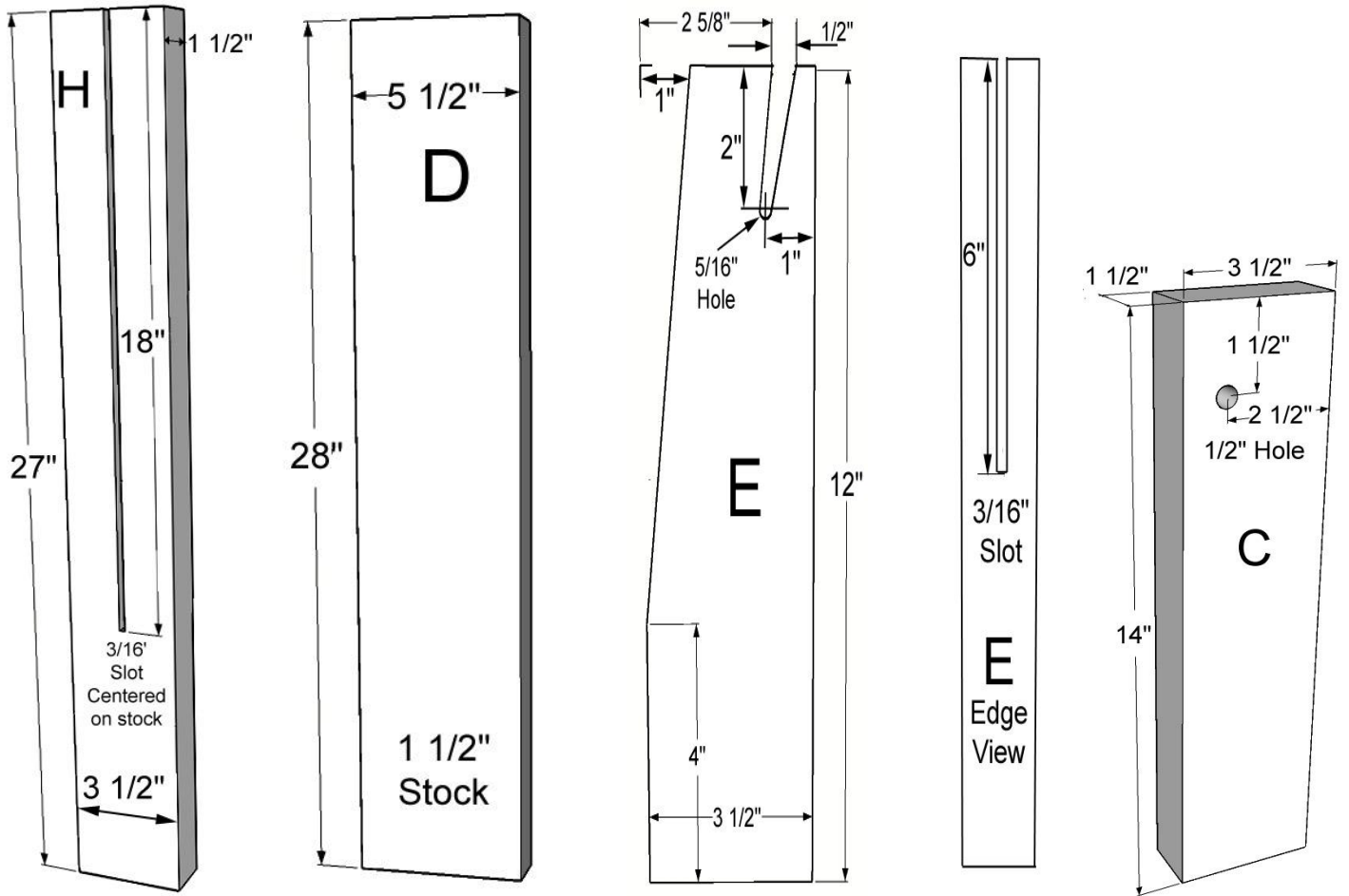

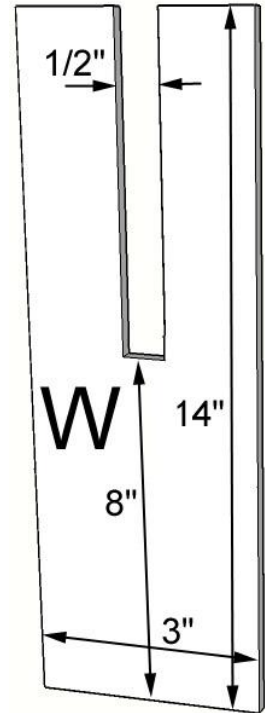
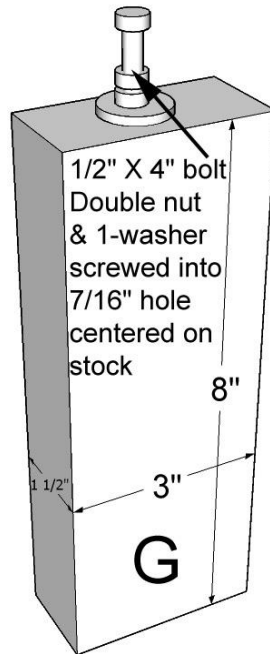
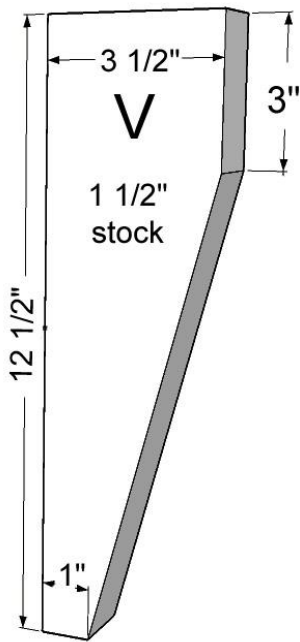
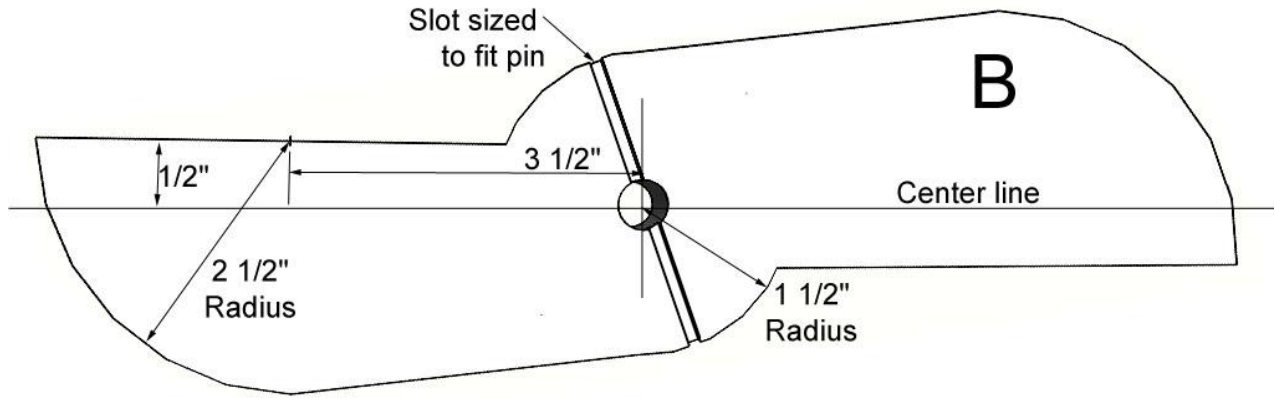

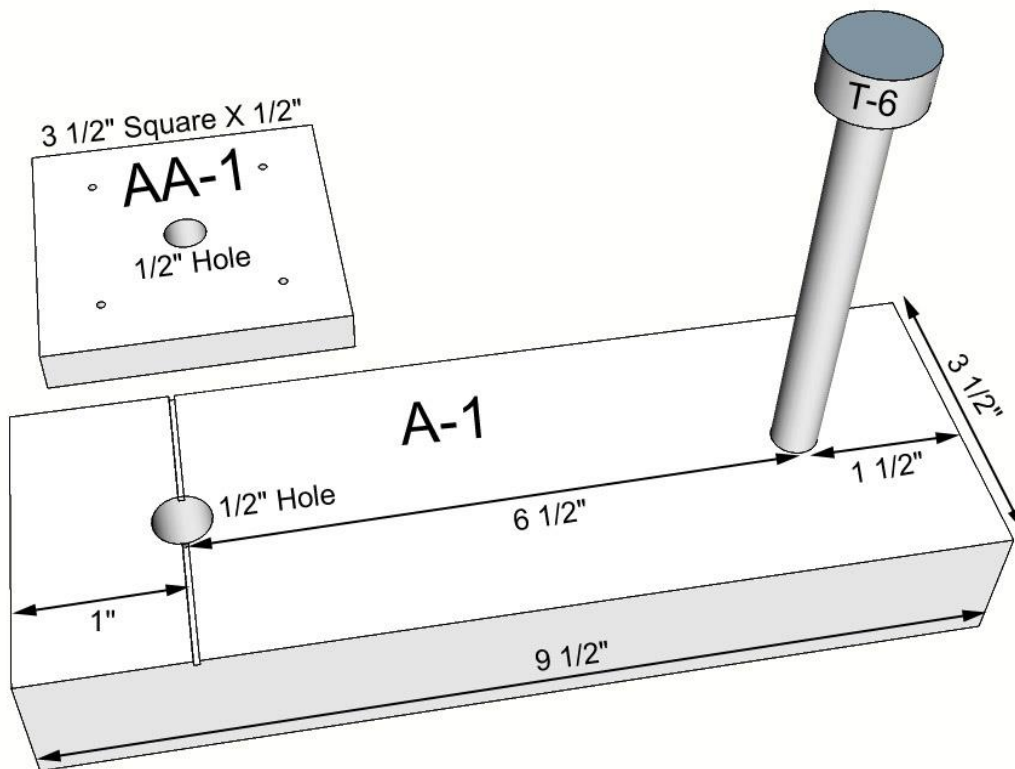
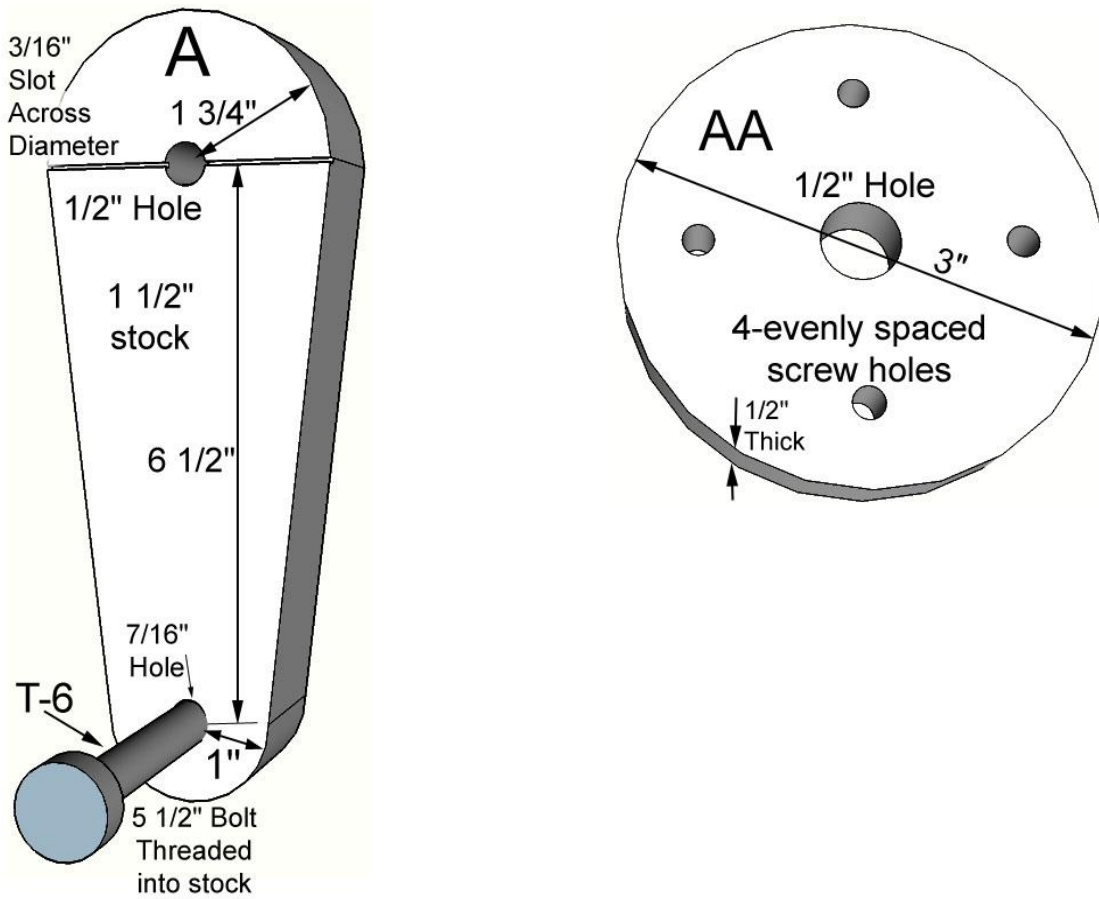

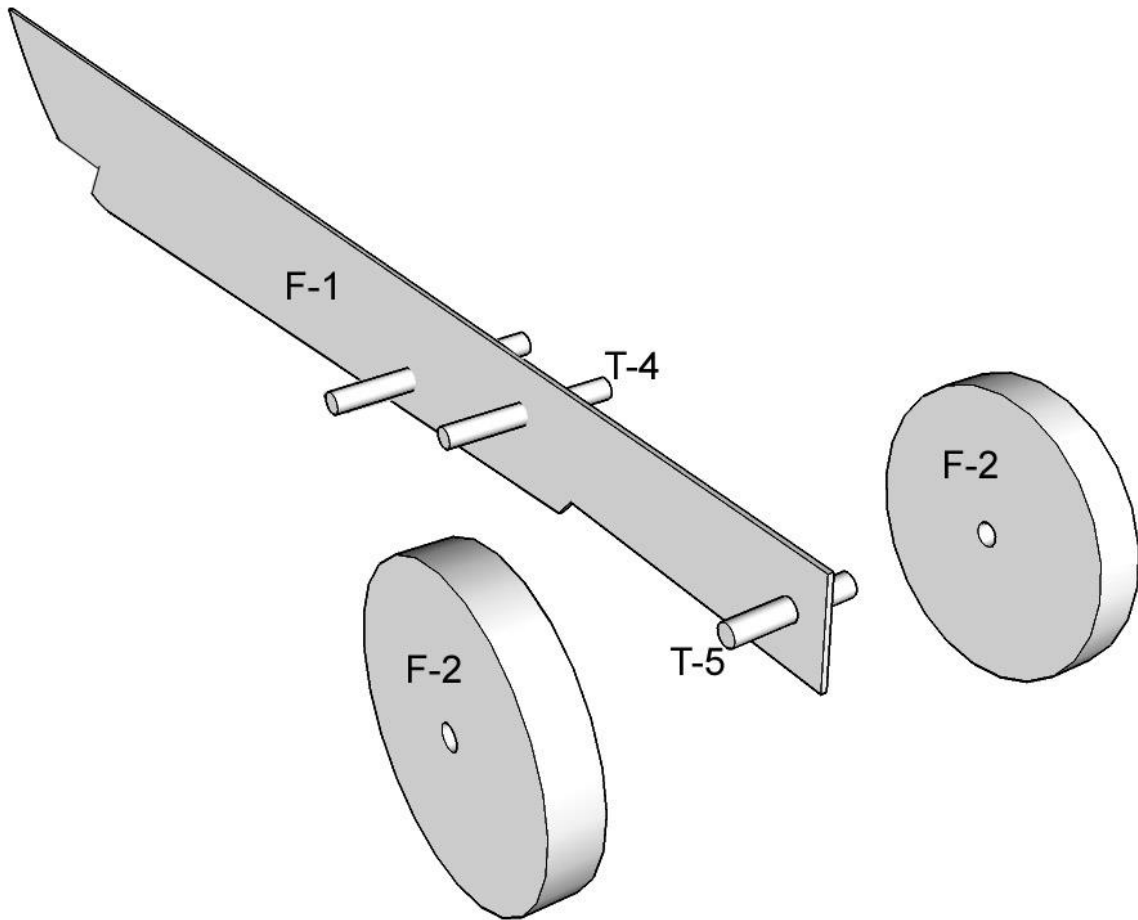
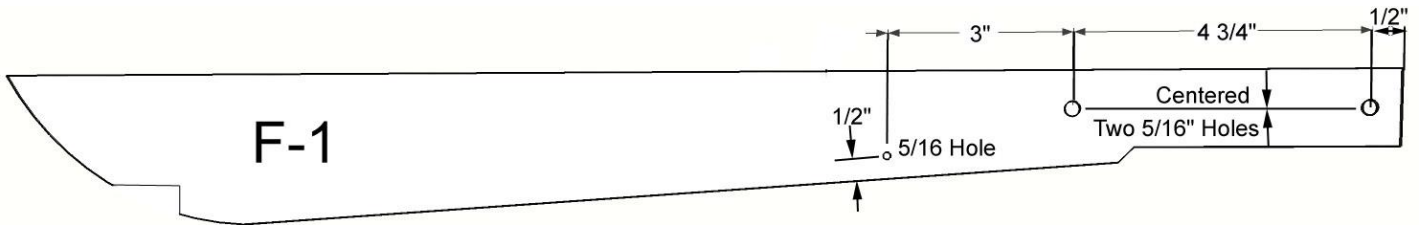
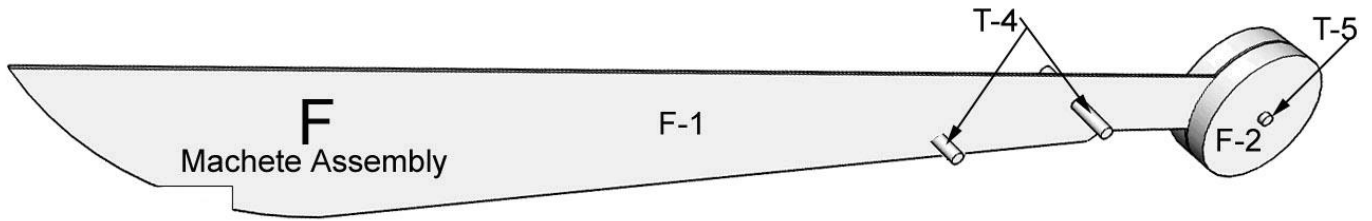

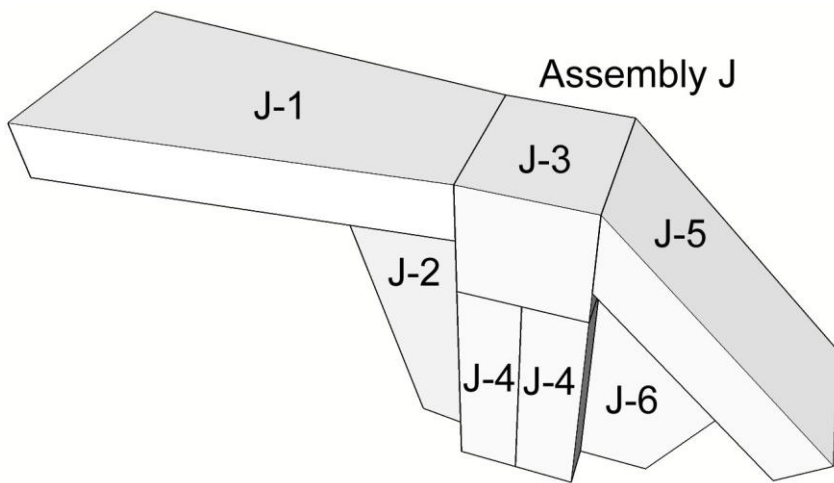
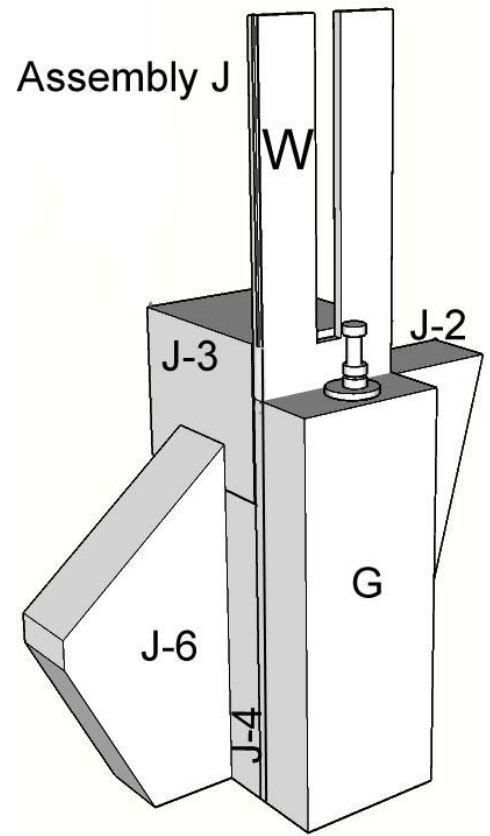
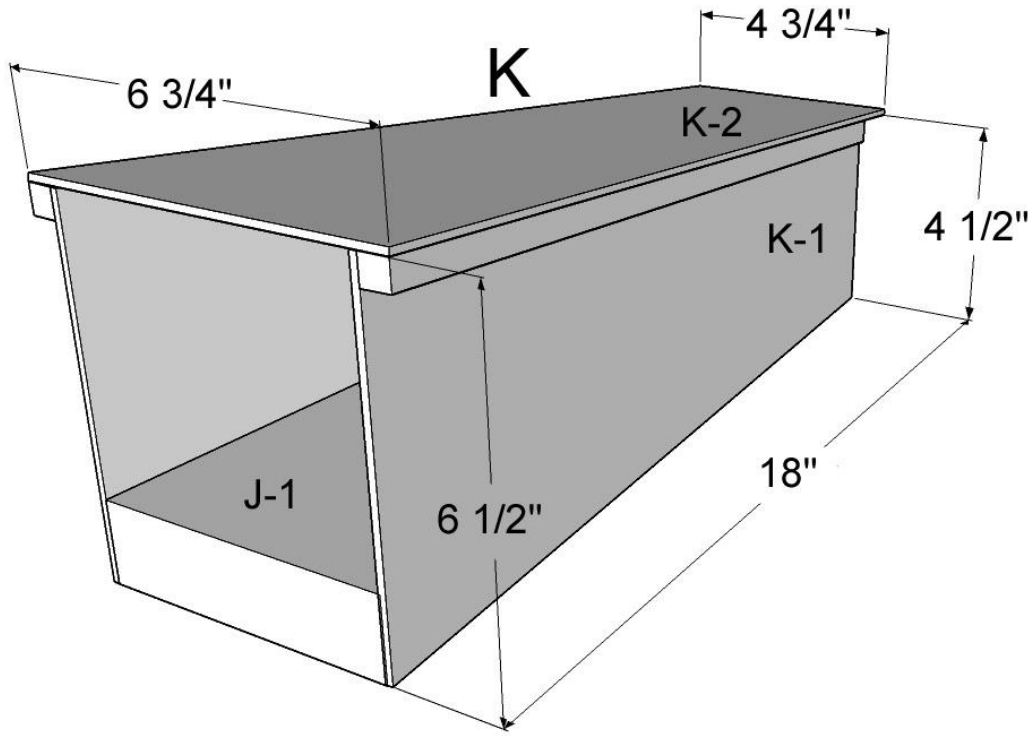

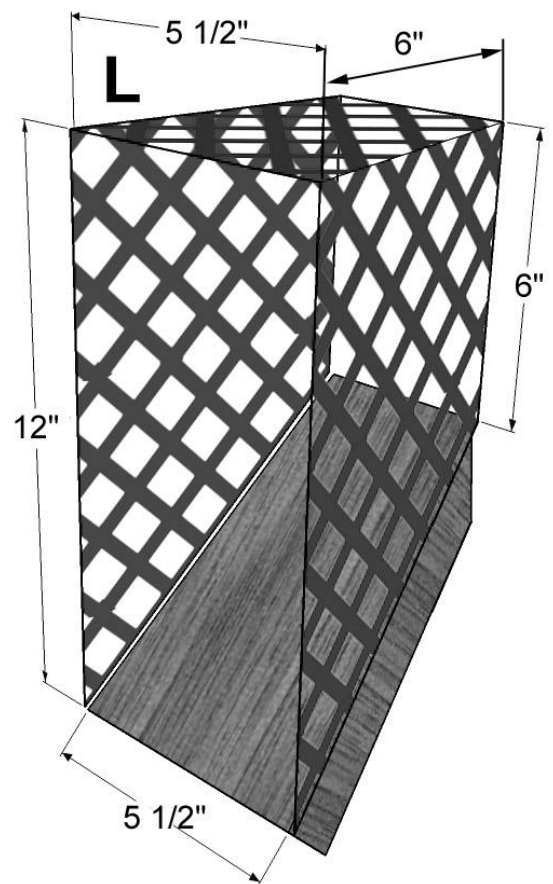
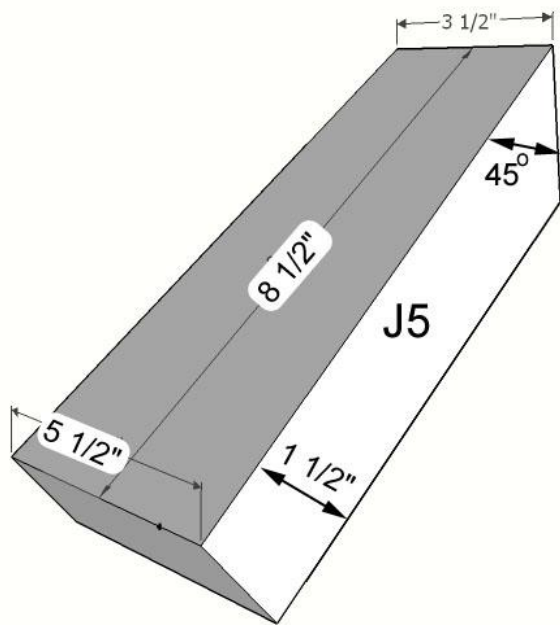
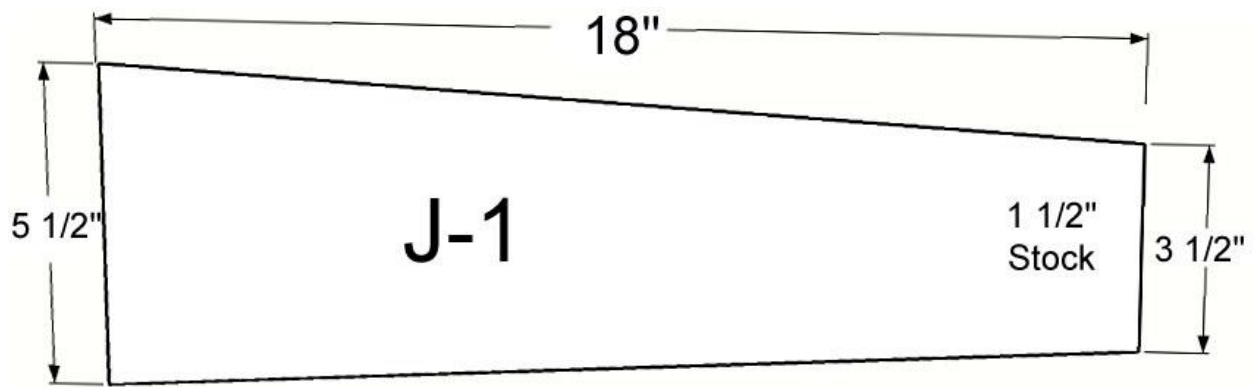

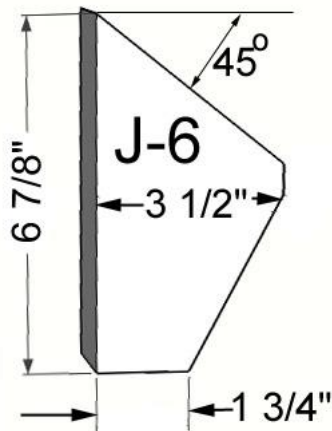
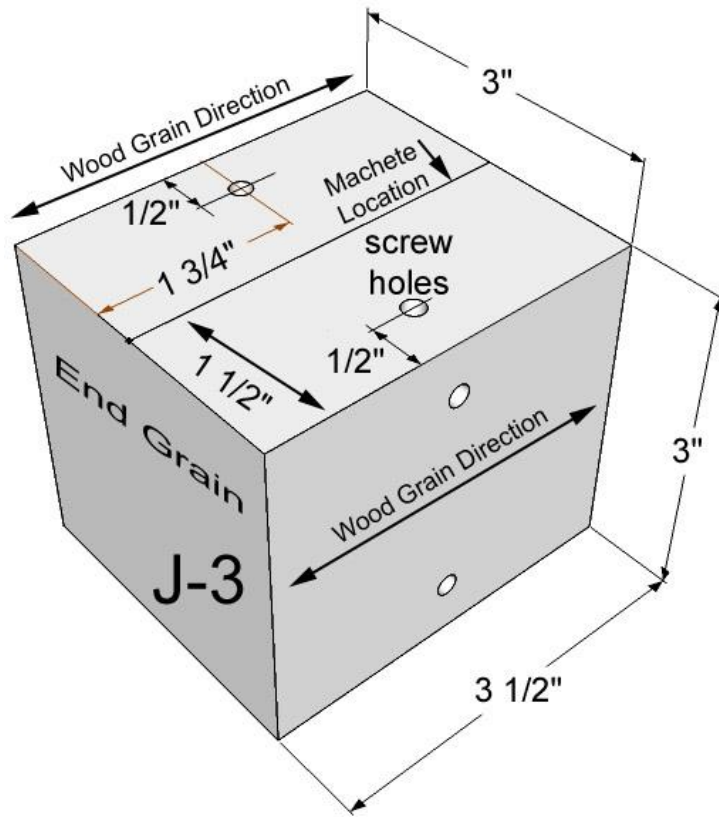

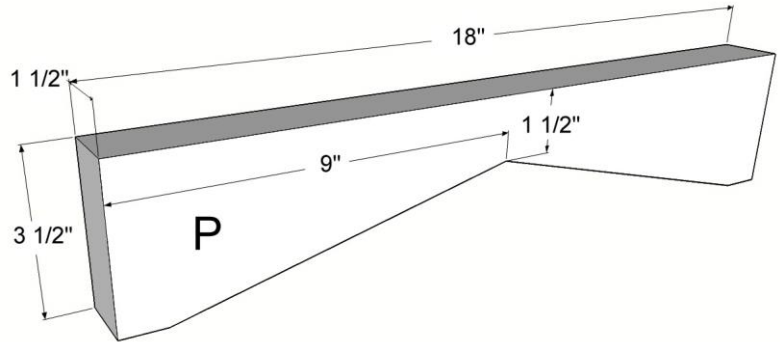
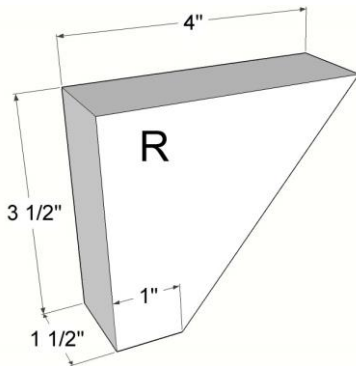
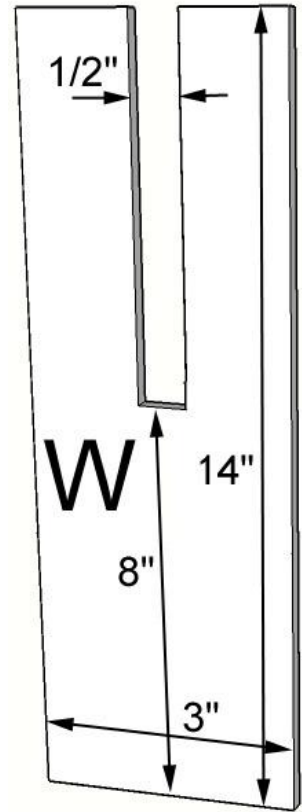
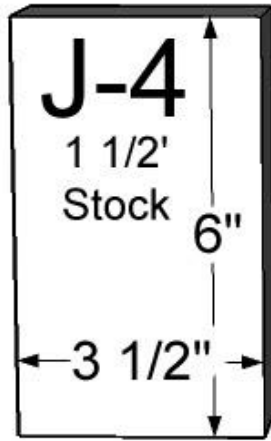
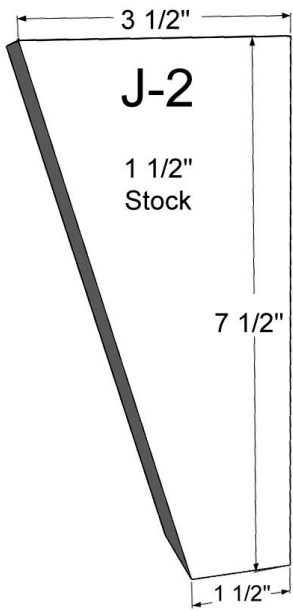

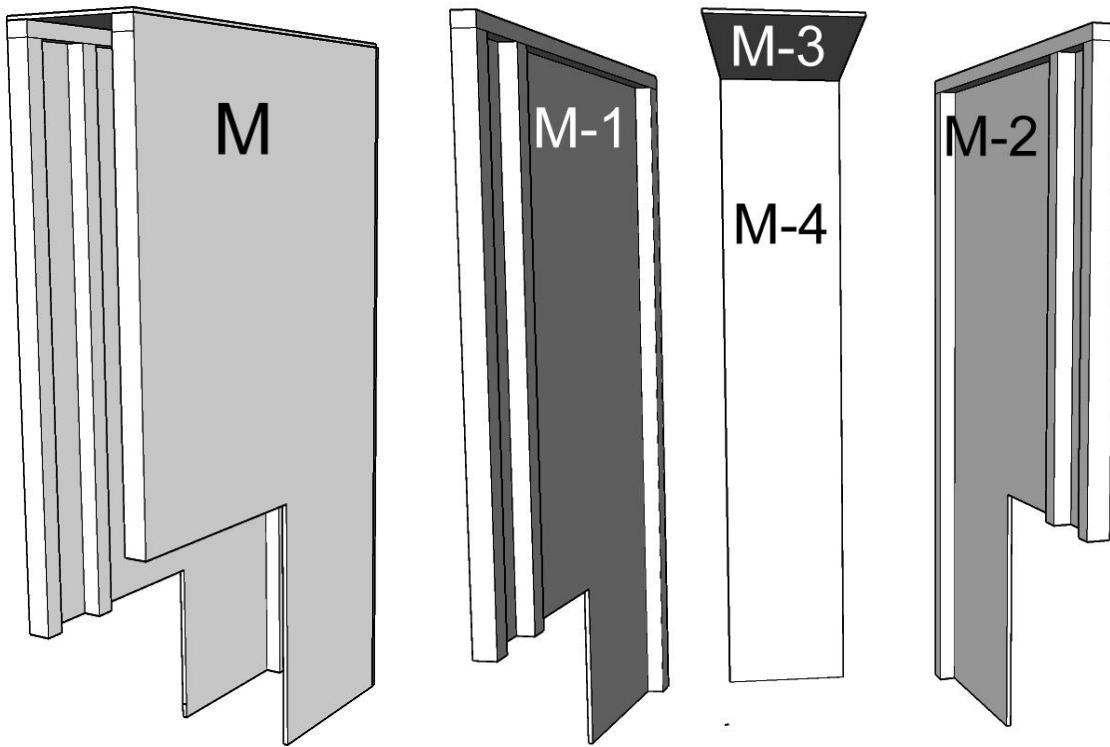
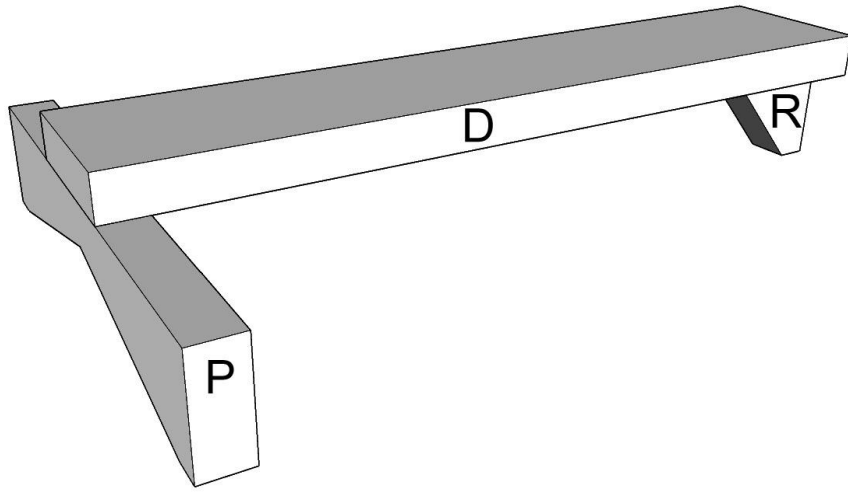

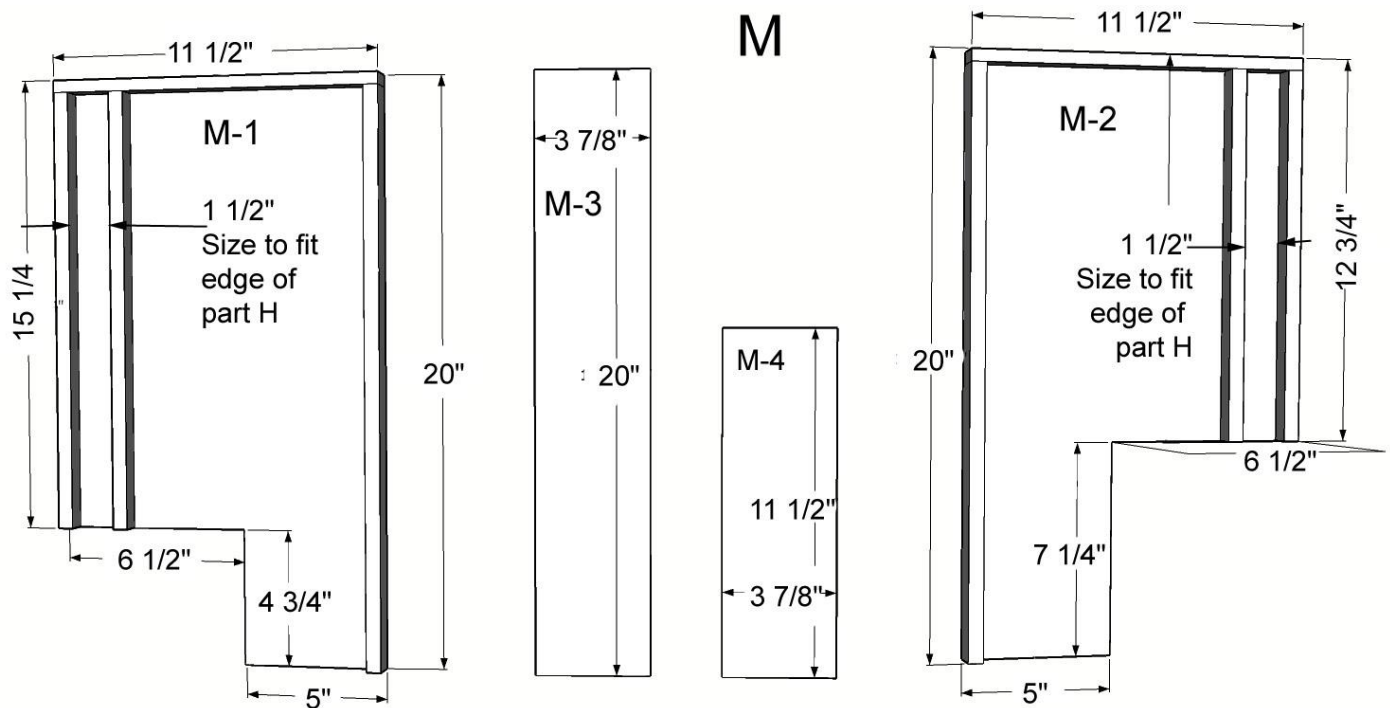

Wood frame is from 1/2" X 1/2" stock.

Safety First !
 Keep Shield on
 When Chopping